

## CONDOR II DUAL WAVEBAND INFRARED DETECTOR

**SELEX Galileo designs, develops and manufactures Infrared (IR) detectors at its dedicated facility in Southampton, UK. With a reputation for providing customers with the best in high performance and cost-effective technology for IR camera systems, SELEX Galileo offers a unique level of expertise.**

The Condor II Dual Waveband Infrared (DWIR) detector is a 640 x 512 Mercury Cadmium Telluride (MCT), Integrated Detector Cooler Assembly (IDCA), designed for high performance imaging in the 3 - 5 $\mu$ m Medium Wave Infrared (MWIR) and 8 - 10 $\mu$ m Long Wave Infrared (LWIR) wavebands.

Each of the 640 x 512 pixels in the array can be switched between MWIR and LWIR sensitivity mode by changing the bias voltage on the device, ensuring spatial coherence between the two bands. By integrating the photocurrent from each band in separate storage cells at the pixel, both bands can be captured and output within a single frame period, optimising the temporal coherence between bands. The entire storage capacity for each pixel can also be dedicated to either of the MWIR or LWIR bands, thus providing user selectable and interchangeable high performance MWIR, LWIR or DWIR operation.

Using the SELEX Galileo MCT process, the Condor II DWIR detector provides the highest environmental integrity along with the superior performance of focal plane detectors.

### MAIN FEATURES

- Snapshot or interlaced operation
- Simple to use
- Concurrent 3 - 5 $\mu$ m and 8 - 10 $\mu$ m operation
- Dedicated 3 - 5 $\mu$ m operation
- Dedicated 8 - 10 $\mu$ m operation
- High electro-optic performance with low crosstalk, automatic anti-blooming at the pixel level and excellent sensitivity
- Windowing gives enhanced frame rates over selected areas of the array
- Single sensor solution for Medium Wave (MW) and Long Wave (LW) without compromise
- Combination of wave bands provides improved DRI over 1st & 2nd Generation
- Wave band switching to optimise performance in all imaging conditions

### KEY BENEFITS

- Low cost
- High resolution
- High frame rate
- High sensitivity
- Reduction in false alarm detection

## Condor II Dual Waveband Infrared Detector



Detector manufacture and test facilities

### TECHNICAL SPECIFICATIONS

#### Format

Array	640 x 512 pixels
Pixel Pitch	24µm
Active Area	15.36 x 12.29mm

#### Typical Performance

NETD (median) LW	28mK (22mk dedicated LW)
NETD (median) MW	28mK (11mk dedicated MW)
Pixel Operability	>99%

#### Interface Parameters

Modes	Snapshot or interlaced
Configuration Control	Single serial interface
Output Voltage Range	2.8V
Charge Capacity (dedicated)	
LW	8 x 10 <sup>6</sup> electrons
MW	8 x 10 <sup>6</sup> electrons
Number of Outputs	8
Pixel Rate	Up to 10MHz per output
Intrinsic MUX noise	50µV rms max
Array Operating Temperature	80K nominal
Nominal Operating Voltage	6V
Minimum Pins for Operation	26
Number of Input Clocks	1
Window Material	Germanium
Window Thickness	1.73mm
Cold Filter Material	Silicon
Cold Filter Thickness	0.4mm

#### ICDA

Weight	<750g
Power Consumption	<10W steady state
Cooling Engine	Rotary Stirling engine
Operating Temperature Range	-40 °C to +70 °C

#### LINEAR ENGINE VARIANT

Weight	950g
Power Consumption	<15W steady state
Cooling Engine	Linear Stirling engine
Operating Temperature Range	-40 °C to +70 °C

#### IDCA

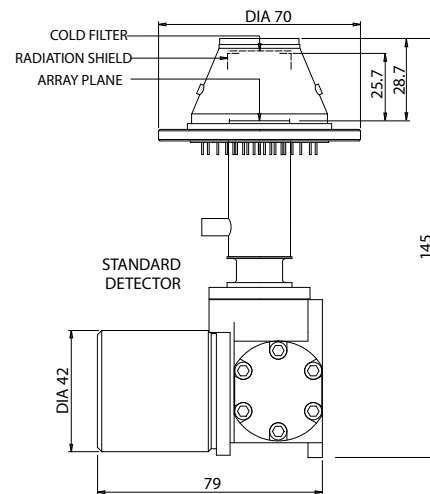

#### LINEAR ENGINE VARIANT

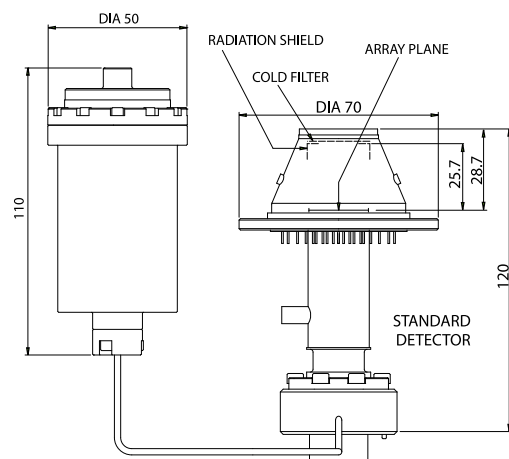

All dimensions are in millimetres

For more information please email [infrared.sales@selexgalileo.com](mailto:infrared.sales@selexgalileo.com)

SELEX Galileo Ltd, A Finmeccanica Company

Millbrook Industrial Estate, Southampton, Hampshire, SO15 0LG, United Kingdom, Tel: +44 (0) 23 8070 2300, Fax: +44 (0) 23 8031 6777

This publication is issued to provide outline information only and is supplied without liability for errors or omissions. No part of it may be reproduced or used unless authorised in writing.

We reserve the right to modify or revise all or part of this document without notice.

2010 © Copyright SELEX Galileo Ltd

[www.selexgalileo.com](http://www.selexgalileo.com)

SELEXGALILEO\UK\Dsh-075\011001\mjg