

# PYROELECTRIC DLATGS INFRARED DETECTORS FOR INSTRUMENTATION

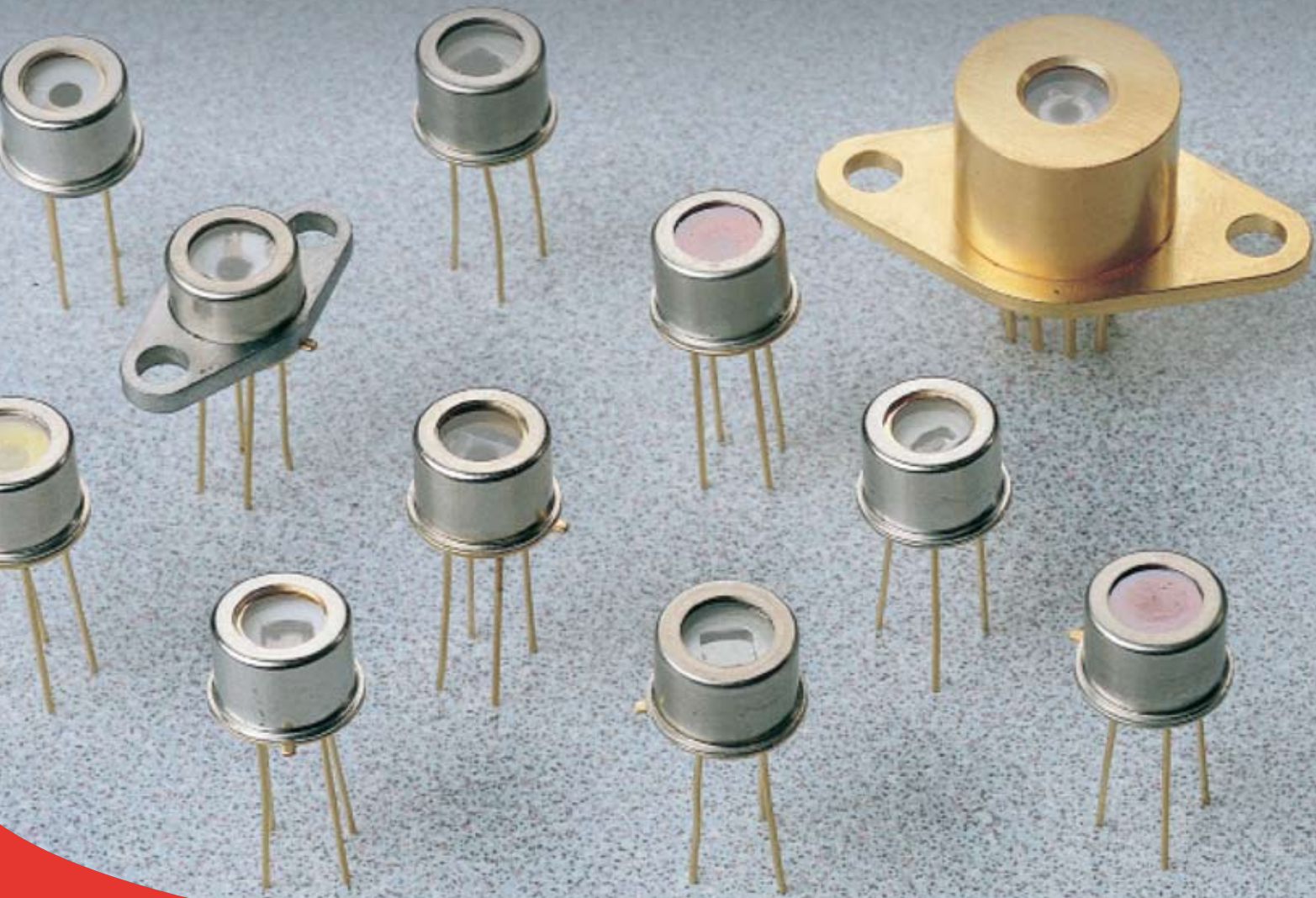

**SELEX GALILEO**

A Finmeccanica Company

## PYROELECTRIC DLATGS INFRARED DETECTORS FOR INSTRUMENTATION

**SELEX GALILEO is the leading manufacturer of DLATGS detectors for Infrared (IR) spectrometers. This position has been achieved by supplying high performance detectors at competitive prices to major IR spectrometer manufacturers all over the world.**

The crystal growth process for DLATGS (deuterated L-alanine doped triglycene sulphate) detectors was developed by SELEX GALILEO and unrivalled production skills have enabled the business to continue to expand.

DLATGS detectors are pyroelectric and can be operated uncooled or with temperature stabilisation.

They are supplied in a range of element sizes with options of hermetic sealing, parylene coating, filter material, pin configuration and performance characteristics.

SELEX GALILEO is the leading supplier of high performance DLATGS detectors for use in FT-IR instruments.

## PYROELECTRIC INFRARED DETECTORS FOR INSTRUMENTATION

### TECHNICAL SPECIFICATION

#### Electrical

Recommended supply voltage	+8 to 10V
Maximum supply voltage	+25V
Typical output impedance	3.5k $\Omega$
Recommended source load resistor	47k $\Omega$
Integral JFET Pre-amplified	
with gate resistance of 10 or 30G $\Omega$	99,104,105,108 series
with gate resistance of 100G $\Omega$	106 series

#### Environmental

Operating temperature:	-20 to 55 °C
Storage temperature:	-20 to 70 °C
Storage humidity:	<50% RH
Operating frequency range:	10 to >3000Hz

#### Standard Detector - T05 Package

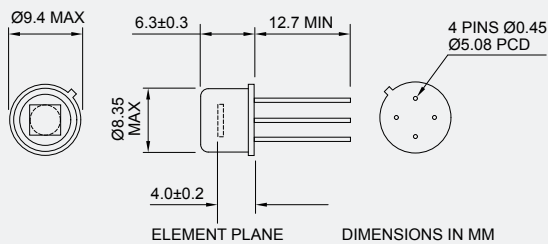

#### Temperature Stabilised - T037 Package

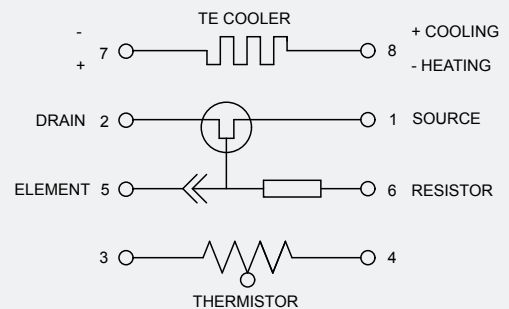
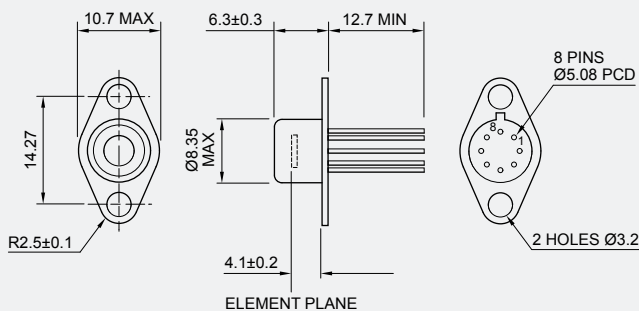

#### Temperature Stabilised - T066 Package

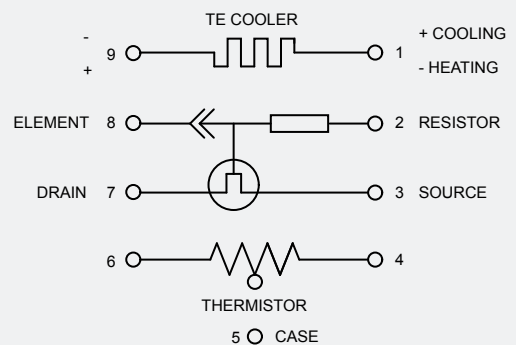
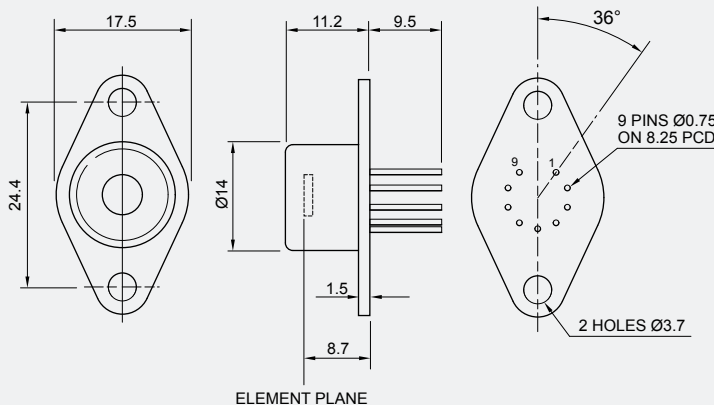

## KEY FEATURES

- DLATGS is one of the highest performing commercial pyroelectric materials available today
- Doped with Deuterium to raise Curie temperature to ~ 59°C
- Doped with L-alanine to prevent permanent depoling after excursions above Curie temperature
- Broad spectral response
- Standard detector supplied in a TO5 package
- Temperature stabilisation available in TO37 and TO66 type packages
- Variety of pinning configurations
- Range of thermal time constants from 4ms to 140ms
- Range of element sizes from 0.25mm to >3mm, round and square
- Choice of windows
- Custom designs considered
- Hermetic sealing of window, or Parylene coating for improved environmental durability.



DLATGS Crystal



FTIR Spectrometer

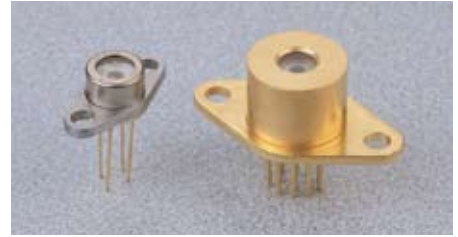

TE Stabilised DLATGS IR Detectors

## PERFORMANCE

Typical Performance Data for 2mm diameter element, excluding window:

Detector Series	Performance Category	Thermal Time Constant	10 Hz		100 Hz		1000 Hz	
			Responsivity V/W	D* 10E8cm <sup>2</sup> /Hz/W	Responsivity V/W	D* 10E8cm <sup>2</sup> /Hz/W	Responsivity V/W	D* 10E8cm <sup>2</sup> /Hz/W
<b>99</b>	High Energy	18 ms	2440	6.6	300	6.6	30	3.5
<b>104</b>	Very High Energy	4 ms	-	-	230	3.3	30	2.3
<b>105</b>	High Performance	65 ms	2060	12.6	255	5.5	25	2.5
<b>106</b>	High Performance	140 ms	2150	18	215	9.8	21.5	2.6
<b>108</b>	High Energy	18 ms	1880	5.0	275	5.0	23	2.7

NOTE:

- All measurements refer to unity gain at the detector
- Test data obtained using a Black Body test
- Noise related measurements correspond with unit bandwidth
- Measurements taken at 22°C

### Typical Relative Responsivity, D\* and NEP for Detector Series 99

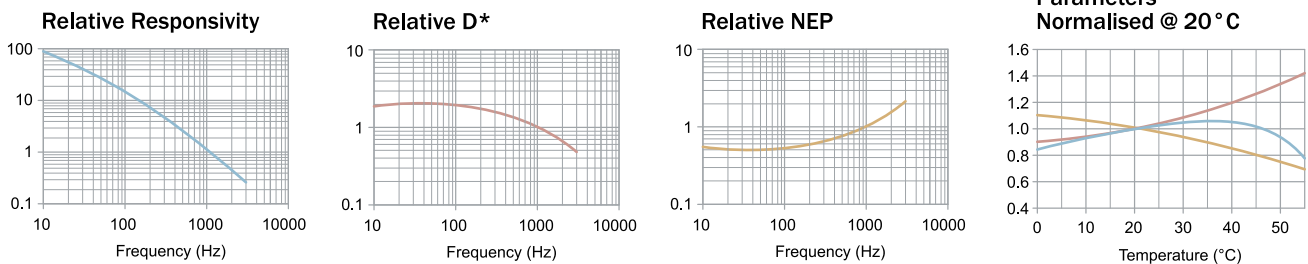

## WINDOWS

Available windows include: CsI, KBr, KRS-5, CaF<sub>2</sub>, BaF<sub>2</sub>, ZnSe, ZnSe-Ar, Polythene and Sapphire.

Others may be available on request.

For greater environmental durability, soft materials may be coated with Parylene, and harder materials may be hermetically sealed.

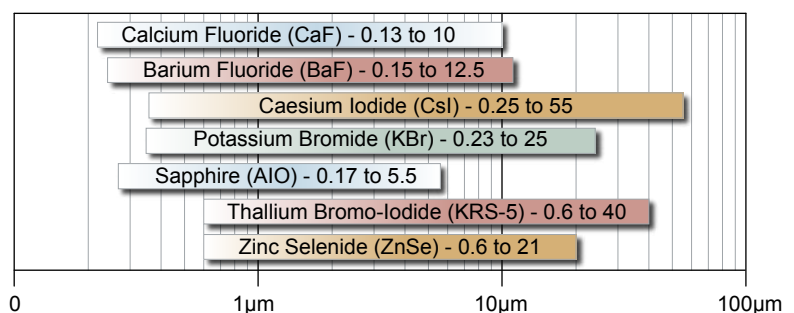

For more information please email [infrared.sales@selexgalileo.com](mailto:infrared.sales@selexgalileo.com)  
**SELEX Galileo Ltd**, A Finmeccanica Company

PO Box 217, Millbrook Industrial Estate, Southampton, Hampshire, SO15 0LG, United Kingdom, Tel: +44 (0) 23 8070 2300, Fax: +44 (0) 23 8031 6777

This publication is issued to provide outline information only and is supplied without liability for errors or omissions. No part of it may be reproduced or used unless authorised in writing.  
We reserve the right to modify or revise all or part of this document without notice.

2010 © Copyright SELEX Galileo Ltd

[www.selexgalileo.com](http://www.selexgalileo.com)

SELEXGALILEO\UK\Brc073\071101\mjpg