

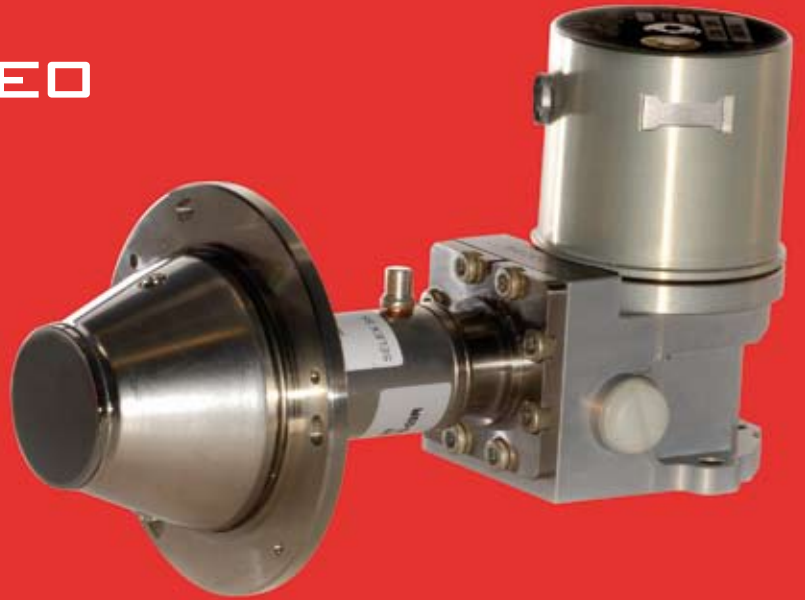

SELEX GALILEO

A Finmeccanica Company



HARRIER LONG WAVE INFRARED DETECTOR

SELEX Galileo, designs, develops and manufactures Infrared (IR) detectors at its dedicated facility in Southampton, UK. With a reputation for providing customers with the best in high performance and cost-effective technology for IR camera systems, SELEX Galileo offers a unique level of expertise.

The Harrier Long Wave Infrared (LWIR) detector is a 640 x 512 Mercury Cadmium Telluride (MCT) Integrated Detector Cooler Assembly (IDCA). The Harrier LWIR detector is designed for very high performance imaging in the 8 - 10 μ m waveband.

Using the SELEX Galileo MCT process, the Harrier LWIR detector provides the highest environmental integrity along with the superior performance of focal plane detectors.

MAIN FEATURES

- Snapshot or interlaced operation
- Simple to use
- Long Wave (LW) 8 - 10 μ m
- High electro-optic performance with low crosstalk, automatic anti-blooming at the pixel level and excellent sensitivity
- Windowing gives enhanced frame rates over selected areas of the array
- Highest LW technology performance available in the world
- Longest LW technology DRI ranges
- Reduced stare time, less motion blur than QWIP detectors
- High performance in low scene temperature

KEY BENEFITS

- Low cost
- High resolution
- High frame rate
- High sensitivity

Harrier Long Wave Infrared Detector



Detector analysis and testing facilities

TECHNICAL SPECIFICATIONS

Format

Array	640 x 512 pixels
Pixel Pitch	24µm
Active Area	15.36 x 12.29mm

Typical Performance

NETD (median)	17mK (12mK interlaced)
Pixel Operability	>99.5%

Interface Parameters

Modes	Snapshot or interlaced
Configuration Control	Single serial interface
Output Voltage Range	2.5V
Charge Capacity	2.5 x 10 ⁷ electrons
Number of Outputs	8
Pixel Rate	Up to 10MHz per output
Intrinsic MUX noise	50µV rms
Array Operating Temperature	Up to 90K
Nominal Operating Voltage	6V
Minimum Pins for Operation	20
Number of Input Clocks	1
Window Material	Germanium
Window Thickness	1.73mm
Cold Filter Material	Silicon
Cold Filter Thickness	0.4mm

IDCA

Weight	<750g
Power Consumption	<10W steady state
Cooling Engine	Rotary Stirling engine
Operating Temperature Range	-40 °C to +70 °C

LINEAR ENGINE VARIANT

Weight	950g
Power Consumption	<15W steady state
Cooling Engine	Linear Stirling engine
Operating Temperature Range	-40 °C to +70 °C

IDCA

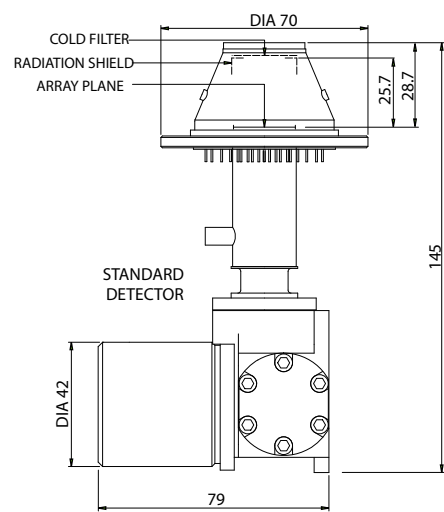

LINEAR ENGINE VARIANT

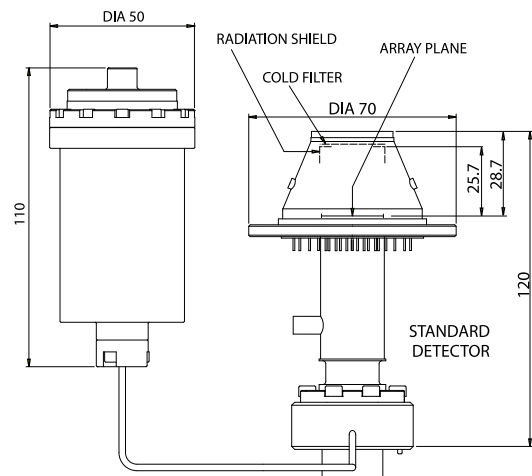

All dimensions in millimetres

For more information please email Infrared.sales@selexgalileo.com

SELEX Galileo Ltd, A Finmeccanica Company

Millbrook Industrial Estate, Southampton, Hampshire, SO15 0LG, United Kingdom, Tel: +44 (0) 23 8070 2300, Fax: +44 (0) 23 8031 6777

This publication is issued to provide outline information only and is supplied without liability for errors or omissions. No part of it may be reproduced or used unless authorised in writing.

We reserve the right to modify or revise all or part of this document without notice.

2010 © Copyright SELEX Galileo Ltd

www.selexgalileo.com

SELEXGALILEO\UK\Dsh-072\011001\mjpg