

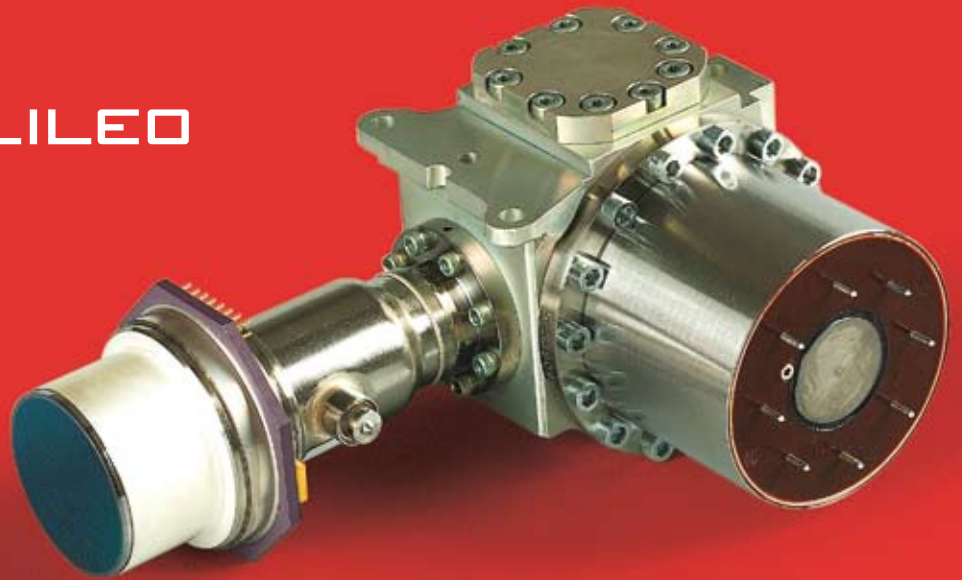

SELEX GALILEO

A Finmeccanica Company



OSPREY-S MEDIUM WAVE INFRARED DETECTOR

SELEX Galileo designs, develops and manufactures Infrared (IR) detectors at its dedicated facility in Southampton, UK. With a reputation for providing customers with the best in high performance and cost-effective technology for IR camera systems, SELEX Galileo offers a unique level of expertise.

The Osprey-S Medium Wave Infrared (MWIR) detector is a compact lightweight 384 x 288 Mercury Cadmium Telluride (MCT) Integrated Detector Cooler Assembly (IDCA). The Osprey-S MWIR detector is designed for high performance, low cost imaging in the 3 - 5 μ m waveband.

Using the SELEX Galileo MCT process, the Osprey-S MWIR detector provides the highest environmental integrity along with the superior performance of focal plane detectors.

MAIN FEATURES

- Snapshot operation
- Simple to use
- Medium Wave (MW) 3 - 5 μ m
- Small element pitch enables miniaturisation of the Dewar assembly and optics
- High electro-optic performance with low crosstalk, automatic anti-blooming at the pixel level and excellent sensitivity
- Higher operating temperature than InSb
 - Longer cooler life
 - Less in-service support
 - Lower through-life cost

KEY BENEFITS

- Low cost
- Light weight
- Compact



Detector production and test facilities

TECHNICAL SPECIFICATIONS

Format

Array	384 x 288 pixels
Pixel Pitch	20um
Active Area	7.68 x 5.76mm

Typical Performance

NETD (median)	14mK
Pixel Operability	>99.97%

Interface Parameters

Modes	Snapshot or rolling reset
Configuration Control	Single serial interface
Output Voltage Range	2.5V
Charge Capacity	1.2 x 10 ⁷ electrons
Number of Outputs	4
Pixel Rate	Up to 10MHz per output
Intrinsic MUX noise	50uV rms
Array Operating Temperature	90 to 120K
Nominal Operating Voltage	6V
Minimum Pins for Operation	16
Number of Input Clocks	1
Window Material	Germanium
Window Thickness	1.73mm
Cold Filter Material	Silicon
Cold Filter Thickness	0.4mm

IDCA 6W

Weight	350g
Power Consumption	6W steady state
Cooling Engine	Rotary Stirling engine
Operating Temperature Range	-40 °C to +70 °C

IDCA 8W

Weight	500g
Power Consumption	8W steady state
Cooling Engine	Rotary Stirling engine
Operating Temperature Range	-40 °C to +70 °C

IDCA 6W

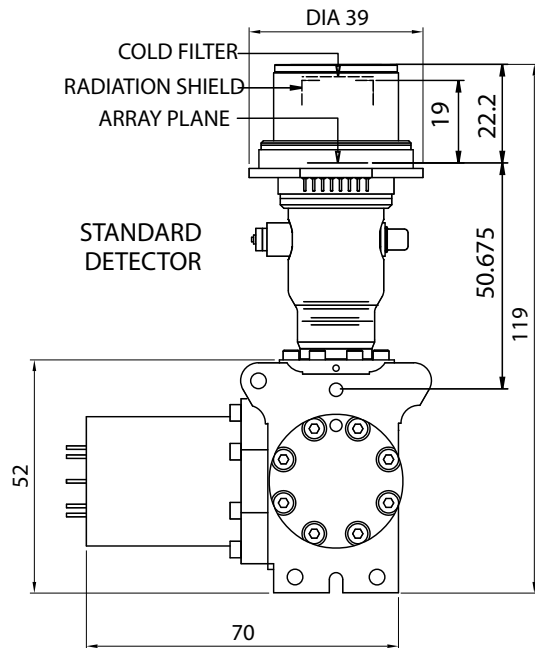

IDCA 8W

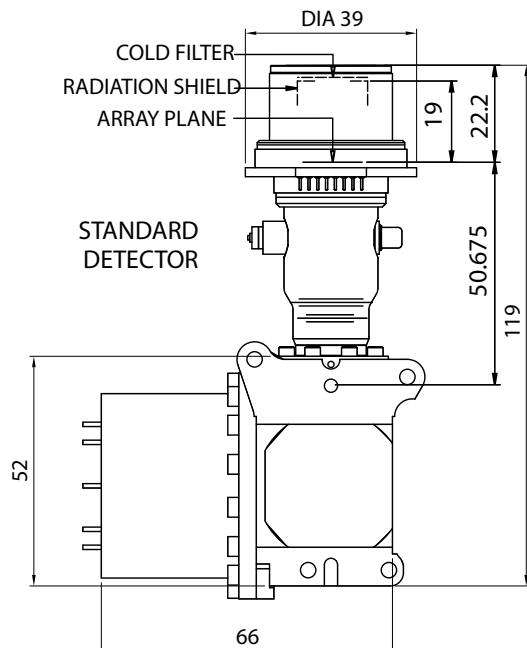

All dimensions in millimetres

For more information please email Infrared.sales@selexgalileo.com

SELEX Galileo Ltd, A Finmeccanica Company

Millbrook Industrial Estate, Southampton, Hampshire, SO15 0LG, United Kingdom, Tel: +44 (0) 23 8070 2300, Fax: +44 (0) 23 8031 6777

This publication is issued to provide outline information only and is supplied without liability for errors or omissions. No part of it may be reproduced or used unless authorised in writing.

We reserve the right to modify or revise all or part of this document without notice.

2010 © Copyright SELEX Galileo Ltd

www.selexgalileo.com

SELEXGALILEO\UK\Dsh-187\011001\mjg