



SELEX GALILEO

A Finmeccanica Company



SWALLOW 3D SHORT WAVE INFRARED DETECTOR

SELEX Galileo designs, develops and manufactures Infrared (IR) detectors at its dedicated facility in Southampton, UK. With a reputation for providing customers with the best in high performance and cost-effective technology for IR camera systems, SELEX Galileo offers a unique level of expertise.

The Swallow IR detector offers a state-of-the-art solution for 3D laser-gated imaging applications, providing extremely high sensitivity and fast temporal gating. The detector is based on avalanche photodiodes, which provide almost noise-free signal gain under control of an externally applied voltage.

The detector comprises a compact, lightweight, 320 x 256 Mercury Cadmium Telluride (MCT), Integrated Detector Cooler Assembly (IDCA). The Swallow detector is designed to be used for laser gated imaging at the eye-safe 1.5 μm wavelength.

Using the SELEX Galileo MCT process, the Swallow detector provides the highest environmental integrity along with the superior performance of focal plane detectors.

MAIN FEATURES

- Snapshot operation
- Simple to operate
- Small element pitch enables miniaturisation of the Dewar assembly and optics
- High electro-optic performance with low crosstalk and blooming
- Sensitivity as low as 10 photons
- Fast gating controlled by external TTL pulses
- Very high extinction ratio outside of gate
- Highest Performing Active Imaging
- Range resolution per pixel within the gate to 10cm
- Range depth controlled by external voltage
- Intensity and range information from each pulse

KEY BENEFITS

- Variable signal gain and dynamic range
- Low cost
- Light weight
- Compact



Detector manufacture and test facilities

TECHNICAL SPECIFICATIONS

Format

Array	320 x 256 pixels
Pixel Pitch	24µm
Active Area	7.68 x 6.14

Typical Performance

Median NEPh	<30 photons
Pixel Operability	>99%

Interface Parameters

Modes Snapshot	
Configuration Control	Single serial interface
Output Voltage Range	3V
Charge Capacity	1 x 10 ⁵ electrons
Number of Outputs	4
Pixel Rate	Up to 5MHz per output
Array Operating Temperature	90K nominal
Nominal Operating Voltage	7V
Minimum Pins for Operation	16
Number of Input Clocks	1
Window Material	Silicon
Window Thickness	1.25mm
Cold Filter Material	None
Cold Filter Thickness	N/A

IDCA 6W

Weight	350g
Power Consumption	6W steady state
Cooling Engine	Rotary Stirling engine
Operating Temperature Range	-40 °C to +70 °C

IDCA 8W

Weight	500g
Power Consumption	8W steady state
Cooling Engine	Rotary Stirling engine
Operating Temperature Range	-40 °C to +70 °C

IDCA 6W

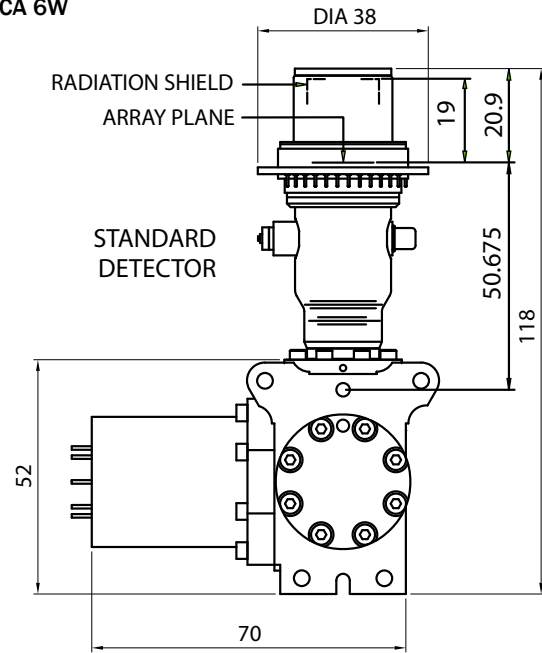

IDCA 8W

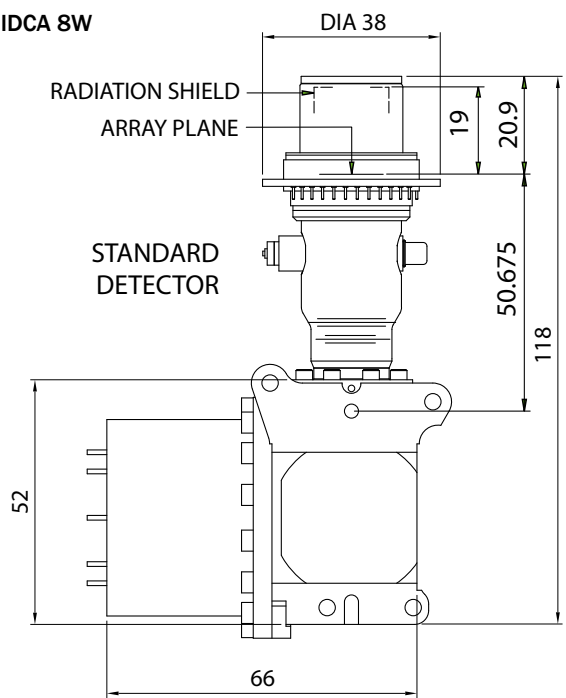

All dimensions in millimetres

For more information please email Infrared.sales@selexgalileo.com

SELEX Galileo Ltd, A Finmeccanica Company

Millbrook Industrial Estate, Southampton, Hampshire, SO15 0LG, United Kingdom, Tel: +44 (0) 23 8070 2300, Fax: +44 (0) 23 8031 6777

This publication is issued to provide outline information only and is supplied without liability for errors or omissions. No part of it may be reproduced or used unless authorised in writing.

We reserve the right to modify or revise all or part of this document without notice.

2010 © Copyright SELEX Galileo Ltd

www.selexgalileo.com

SELEXGALILEO\UK\Dsh-170\011001\mjg